

V O L V O



Volvo Rigid Haulers 40.8-65.0 t 533-771 hp

R70D

Volvo Construction Equipment

R70D



Safe from the inside out



Stay safe in the FOPS-certified Volvo cab, packed with visibility-enhancing features, such as Volvo Smart View.



Built for the long haul

Achieve long lasting performance and uptime thanks to the straightforward and uncomplicated machine design.

Get up close and personal



Move more – faster

Combining power, effective gearing, and optimum weight distribution, our rigid haulers cut cycle times.



Robust protection

Ensure long component lifecycle with engine protection derate system.



Get back to work fast

Simplify servicing with conveniently grouped essential checkpoints, centrally mounted transmission and operator-friendly dashboard.



Do more with less fuel

Reduce your number one operating cost thanks to the electronic integration between the engine and transmission, and load sensing hydraulics.



No compromises on comfort

Get comfortable with doing more in the Volvo cab, offering HVAC, responsive steering accumulator and easy-to-use controls.



Safe and responsive braking system

Experience fast and safe hauling with the standard transmission and brake retarder, providing total control when operating on steep gradients.



Key to a low cost operation

Drive your operating costs down with proven components from Volvo, durably designed to withstand the test of time.



Profitable payload

Ensure optimum load retention with the D-Series haulers, fitted with an exhaust-heated body to minimize material carry-back.



No feat too steep

Navigate gradients with ease thanks to superb tractive efforts offered by the complete drivetrain design and configuration.



Selectable shift patterns

Haul it all thanks to two integrated payload sensitive transmission gearshift patterns: Power and Economy.

Volvo R70D in detail

Engine		
Model		MTU-2000TA
Type		Four cycle, emission certified, direct injection diesel, water cooled, turbo charged and charge air cooled
Cylinder/configuration		V12
Displacement	l	24
Bore x Stroke	mm	130 x 150
Max. power at	r/min	2 100
Gross power (SAE J1995)	kW	567
	hp	771
Net power	kW	511
	hp	695
Max. torque at	r/min	1 350
Gross torque	Nm	3 323
Engine emissions		Meets USA EPA Tier 2/CARB MOH 40 CFR 89 and EU MOHroads mobile machinery directive, stage 2
Electrical		24 volt negative ground electrical system. Two 12 volt 200 Ah batteries. 7.7 kW (10 hp) electric starter. Neutral start. 100 A alternator.
Altitude - electronic derate	m	3 100
Steering System		
Independent hydrostatic steering with closed-centre steering valve, accumulator and pressure compensating piston pump. Accumulator provides uniform steering regardless of engine speed. In the event of loss of engine power the accumulator provides steering of approximately two lock-to-lock turns. A low pressure indicator light warns of system pressure below 82 bar (1,190 psi). Steering conforms to ISO 5010.		
Maximum tire steering angle	°	42
SAE turning radius	mm	9 760
Clearing radius	mm	11 200
Axles		
Heavy duty axle with full floating axle shafts, single reduction spiral bevel gear differential, and planetary reduction at each wheel		
Standard		
Differential ratio		3.73:1
Planetary reduction		5.8:1
Overall drivetrain reduction		21.63:1
Frame		
Full box section frame rails, integral front bumper, closed-loop crossmember and torque tubes of 290 MPa yield strength steel. Crossmember connections are 655 Mpa (95 000 lbf/in ²) steel castings.		
Body		
Longitudinal 'V' type floor with integral transverse box-section stiffeners. The body is exhaust heated and rests on resilient impact absorption pads. Body floor wear surface: Are high hardness Hardox (360-440 BHN) abrasion resistant steel of yield strength 1 000 MPa (145 000 lbf/in ²)		
Plate thickness		
Floor	mm	19
Sides	mm	10
Front	mm	10
Body volume		
Stuck	m ³	29
Heaped 2:1 (SAE)	m ³	41.5
Tires and Rims		
Tires type		24-35
Rims		17
Consult tyre manufacturers for optimum tyre selection and current + - km/h (ton-mile/h) capacity for application		

Drivetrain		
Transmission		Allison 6620 ORS
Assembly	Mid-mounted in the frame for ease of access with integral torque converter, hydraulic retarder and planetary gearing. Automatic electronic control with softshift feature. Automatic lock-up in all speed ranges.	
Electronic control		CEC2
Maximum speed, forward/reverse		
1st gear	km/h	9.5 / 7.4
2nd gear	km/h	14.2 / 11.0
3rd gear	km/h	18.9
4th gear	km/h	28.2
5th gear	km/h	38.1
6th gear	km/h	57
Suspension		
Front: Volvo manufactured king pin strut-type independent front wheel suspension with self contained, variable rate, nitrogen/oil cylinders.		
Rear: Volvo variable rate nitrogen/oil cylinders with A-frame linkage and lateral stabilizer bar.		
Maximum front strut stroke	mm	235
Maximum rear strut stroke	mm	193
Maximum rear axle oscillation	°	7.5
Brake system		
All hydraulic brake system control. Transmission mounted pressure compensating piston pump provides hydraulic pressure for brakes and steering. Independent circuits front and rear. Each circuit incorporates a nitrogen/hydraulic accumulator which stores energy to provide rapid braking response and emergency supply.		
Parking: Rear brakes applied by spring loaded opposing piston on disc pack, hydraulically released.		
Secondary: Park push button solenoid control applies service and parking brakes. Automatically applies when engine is switched off. Brakes conform to ISO 3450.		
Retardation: Lever control of rear disc brakes or hydraulic retarder in transmission.		
Front brakes type		Dry disc
Front brake diameter	mm	710
Front brakes lining area	cm ²	2 788
Rear brakes type		Volvo force oil cooled, multiple disc
Rear brake lining area	cm ²	67 390
Hoist		
Two body hoist cylinders are mounted between the frame rails. Cylinders are two-stage with power down in the second stage. Float to chassis and over-centre kick-over control.		
System relief pressure	MPa	19
Pump output flow rate	l/min	365
at	r/min	2 100
Body raise time	s	13
Body lower time	s	11.5
Service Refill		
Engine crankcase and filters	l	33
Transmission and filters	l	85
Cooling system	l	236
Fuel tank	l	938
Steering hydraulic tank	l	61
Steering hydraulic system (total)	l	92
Body hydraulic tank	l	258
Body hydraulic and brake cooling system (total)	l	432
Planetaries (total)	l	43
Differential	l	52
Front ride strut (each)	l	25
Rear ride strut (each)	l	21
Power take off	l	4
Weights		
Chassis with hoists	kg	36 190
Body standard	kg	11 500
Net weight	kg	49 573
Maximum payload	kg	65 000
Maximum gross weight*	kg	114 573
Weight distribution (axles)		Front / Rear
- Empty	%	50 / 50
- Loaded	%	34 / 66
*Maximum permissible gross vehicle weight with options, attachments, full fuel tank and payload.		

Specifications

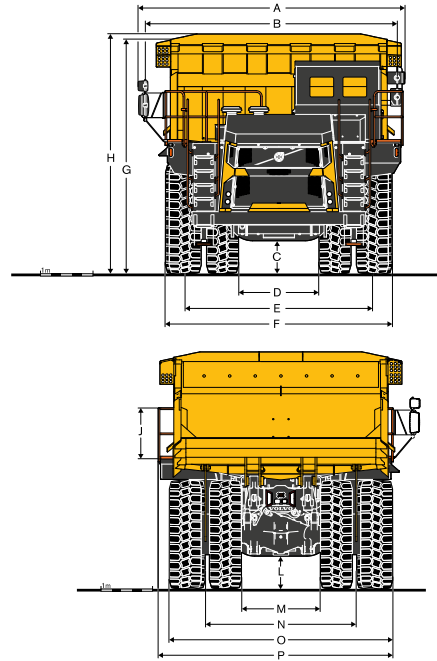
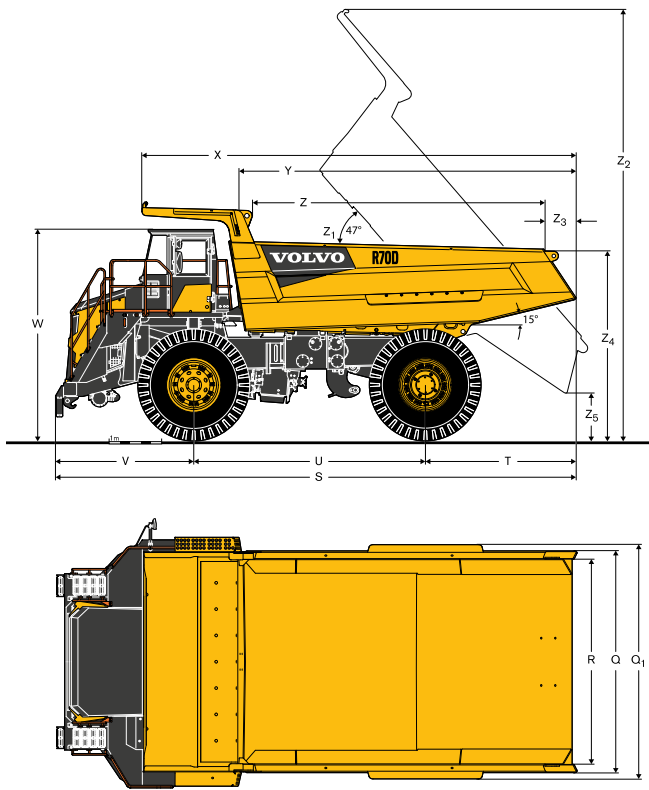

DIMENSIONS		Unit	R70D
A	mm	5 290	
B	mm	4 940	
C	mm	685	
D	mm	2 970	
E	mm	3 660	
F	mm	4 420	
G	mm	-	
H	mm	4 570	
I	mm	-	
J	mm	1 536	
K	mm	1 080	
L	mm	600	
M	mm	1 500	
N	mm	2 995	
O	mm	4 445	
P	mm	-	
Q	mm	4 280	
Q ₁	mm	4 940	
R	mm	3 940	
S	mm	9 905	
T	mm	2 945	
U	mm	4 470	
V	mm	2 490	
W	mm	4 190	
X	mm	8 380	
Y	mm	6 580	
Z	mm	6 200	
Z ₁	°	58	
Z ₂	mm	8 380	
Z ₃	mm	-	
Z ₄	mm	3 785	
Z ₅	mm	460	

Equipment

STANDARD EQUIPMENT

Engine

Charge air cooler
Air cleaner
Direct drive fan
Fuel filter/water separator
Sump guard

Operator environment

2 doors lights
Air conditioning
Body hoist control, servo assisted
CD/radio player
Cup holder
FOPS protection, ISO 3449/SAE J231
Heater/demistor
Horn
Insulation, thermal and acoustic
Interior light
Mirrors
Power port, 24 V & 12 V
Power window (LHS)
360 degree camera visual system
ROPS protection (body cabguard), ISO 3471/SAE J1040
Seat , operator, air suspension
Seat belt, operator 4-point harness
Seat, trainer
Steering wheel, padded with tilt
Storage compartment
Sun visor
Tinted glass
Wiper and washer, windscreen
Gauges
Coolant temperature
Engine oil pressure
Fuel level
Hourmeter
Odometer
Speedometer
Tachometer
Transmission oil temperature

Warning indicator lights

Air cleaner restriction
Air filter restriction indicator
Alternator charging
Body up
Brake cooling oil temperature, high
Brakes front, low pressure
Brakes rear, low pressure
Direction indicator
Engine check
Engine coolant level
Engine coolant temperature
Engine maintenance
Engine oil pressure
Engine overspeed
Engine stop
Headlight main beam
In-converter
Parking brake
Retarder active
Steering and brake tank, low oil level
Steering filter restriction
Steering, low pressure
Transmission check
Transmission oil filter restriction
Transmission oil temperature, high

Audible alarms

Brakes front, low pressure
Brakes rear, low pressure
Steering, low pressure

STANDARD EQUIPMENT

Electrical system

Alternator, 70 A
Alternator , 100 A
Batteries, 2 x 12 V, 180 Ah
Batteries, 2 x 12V, 200 Ah
Battery master switch, electrically operated
Direction indicators and hazard warning
Headlights
In-cab diagnostics, engine/transmission
Reverse alarm / reverse light
Side, tail, stop lights (LED)

Transmission

Body-up reverse interlock
Body-up shift inhibitor
Downshift inhibitor
Filter restriction shift inhibitor
Hydraulic retarder
Neutral start interlock
Shift energy management
Sump guard

Brake system

Brake retarder (rear)
Front dry disc brakes
Hydraulically actuated

Dual circuits

OCDB oil cooler
Oil-cooled multiple-disc (rear)
Park brake integral to rear brake pack

Body

Body down indicator
Exhaust heated
Mud flaps
Operator guard - LHS
Operator guard - RHS
Rock ejectors
Safety locking pins
Tire guards

Other

Diagnostic pressure test points
Exhaust muffler
Handrails on fenders
Tow points, front and rear

OPTIONAL EQUIPMENT

Engine

Inline fuel heater

Operator environment

Mirrors - heated / electrical actuated

Drivetrain

Differential - traction bias

Electrical system

Alternator, 100 A
Auxiliary jump-start receptacle
Beacon - orange cab mounted
Service lighting kit
Ground level isolation switch
Work lighting kit

Body

Body liner plates
Body side extensions -upon request
Tail gate
Body spill guard
On Board Weighing system

Maintenance

Auto lubrication system
Quick oil drain kit
Fire suppression system
-40°C arctic weather protection

Not all products are available in all markets. Under our policy of continuous improvement, we reserve the right to change specifications and design without prior notice. The illustrations do not necessarily show the standard version of the machine.

V O L V O